

Cavalier Electric Water Heater

Installation, Commissioning,
User & Maintenance Instructions

Models:

AMP 200-9	AMP 300-9
AMP 200-18	AMP 300-18
AMP 200-36	AMP 300-36
	AMP 300-54

LV313545 | February 2020





IMPORTANT INFORMATION

These instructions must be read and understood before installing, commissioning, operating or maintaining the equipment.

Preface

Copyright

Copyright © 2019 Lochinvar Ltd.

All rights reserved.

Nothing from this publication may be copied, reproduced and/or published by means of printing, photocopying or by whatsoever means, without the prior written approval of Lochinvar Ltd..

Lochinvar Ltd. reserves the right to modify specifications in this manual.

Trademarks

Brand names in this manual are registered trademarks of their respective owners.

Warranty

Refer to the appendix [Warranty](#) (see 11.6) for the warranty provisions.

Liability

User

Lochinvar accepts no liability when the water heater is not used correctly and requires the user to:

- Read this manual carefully and obey the instructions.
- Ask your installation engineer for advice about the use of the water heater.
- Make sure that the service and maintenance activities are done by a qualified engineer.

Installation engineer

Lochinvar accepts no liability when the water heater is not used correctly and requires the installation engineer to:

- Read this manual carefully and obey the instructions.
- Make sure that the entire water heater installation complies with the applicable regulations.
- Make sure that the water heater is tested before the installation is taken into use.
- Explain the correct use to the user.
- Notify the user when service and maintenance activities are necessary.

- Make sure that you hand over all applicable manuals.

Supplier

The AMP water heater is designed in accordance with the applicable regulations. The water heater is delivered with all necessary documentation to obey these regulations.

Lochinvar accepts no liability for claims from third parties when:

- The instructions for the correct installation of the water heater are not obeyed.
- The instructions for the correct use of the water heater are not obeyed.
- The water heater did not have maintenance at the correct maintenance interval.

For more information, refer to the General Terms of Sales. These are available on request, free of charge.

We believe that this manual provides you with accurate and complete descriptions of all relevant components. If you, nonetheless find errors or inaccuracies in this manual, please inform Lochinvar. This helps us to further improve our documentation.

Compliance

To safely produce domestic hot water, the design and construction of the AMP water heaters is in accordance with:

- The LVD Directive (2006/95/EC)
- The European Pressure Equipment Directive
- The European ECO-Design Directive.
- The European Energy Labeling Directive

Refer to the appendix [Declaration of conformity](#) (see 11.5).

Regulations

The installation of the equipment MUST be in accordance with the relevant requirements of the Building Regulations, I.E.E. Regulations and the bylaws of the local water undertaking.

In addition, the installation should follow the relevant guidance offered in the following documents. It is not practical to list all relevant information due to continuous changes but emphasis is placed on the following documents,

as failure to comply with the guidance given will almost certainly result in an unsatisfactory installation:

- British Standards (BS), especially:
 - BS 6700: 1997 - Design, installation, testing and maintenance of services supplying water for domestic use with buildings and their curtilages
 - BS 67074: 1989 Part 1 and 2 - Application, selection and installation of expansion vessels and ancillary equipment for sealed systems
 - BS 7671: 2008 - Requirements for electrical installations, I.E.E. wiring regulations seventeenth edition
 - CP 342: Part 2 1974 - Code of practice for centralised hot water supply-buildings other than dwellings
- CIBSE Guides
- Clean Air Act
- H.S.E Guidance

Note

Manufacturer's notes must not be taken in any way as overriding statutory obligations.

Contact information

In the event of problems with your electricity or water supply connections or when you have any comments or questions, please contact your supplier.

About this manual

Scope

This manual gives information about safe and correct use of the water heater and how installation, maintenance and service activities have to be done correctly. You must obey the instructions in this manual.

Caution

Read this manual carefully before you start the water heater. It can cause personal injury and damage to the water heater when you do not read the manual and/or do not obey the instructions.

The purpose of this manual is to:

- describe the working principles and layout of the water heater
- explain the safety devices
- highlight possible hazards
- describe the use of the water heater
- describe the installation, service and maintenance of the water heater

This manual has two parts:

- A User part that describes the correct usage of the water heater.
- An Installation, Maintenance and Service part, that describes the correct installation and maintenance procedures.

Target group

The information in this manual applies to three target groups:

- users
- installation engineers
- service and maintenance engineers

The User part is intended for the (end) users. The Installation, Maintenance and Service part is intended for the installation engineers and the service and maintenance engineers.

Notation conventions

This manual uses the following text conventions:

- Numbers between parentheses e.g. (1), refer to elements in a figure that are described by the text.
- Cross-references to sections, tables, figures etc. are underlined and written as (see "..."). In the digital version, the cross-references function as hyperlinks that can be used to navigate through the manual by clicking on them. Example: Safety (see 2).

This manual contains the following text styles for situations that may endanger users/ engineers, cause damage to equipment or need special attention:

Note

A note gives more information on a topic.

Caution
Obey the caution instructions to prevent damage of the water heater.

Warning
Obey the warning instructions to prevent danger of personal injury, and serious damage to the water heater.

Danger
Obey the danger instructions to prevent danger of serious personal injuries or death, and serious damage to the water heater.

Table of contents

Preface	3
Copyright	3
Trademarks	3
Warranty.....	3
Liability	3
Compliance	3
Regulations	3
Contact information	4
About this manual	4
Scope.....	4
Target group.....	4
Notation conventions	4
User Part	6
1 Introduction	6
2 Safety	6
3 Operation	7
3.1 Control components.....	7
3.2 Status of the water heater.....	7
4 Use	7
4.1 Turn on the water heater.....	7
4.2 Turn off the water heater.....	8
Installation, Maintenance and Service Part ...	8
5 Introduction	8
5.1 About the water heater	8
5.2 Working principle	8

6 Safety	8
6.1 Safety instructions.....	8
6.2 Instructions on the water heater	9
6.3 Safety devices	9
6.4 Environmental aspects.....	11
7 Water heater	11
7.1 Structure of the water heater	11
8 Installation	11
8.1 Packaging.....	11
8.2 Conditions.....	11
8.3 Installation diagram	12
8.4 Water connections	13
8.5 Electrical connections	13
8.6 Commissioning	14
8.7 Decommissioning	14
9 Maintenance	14
9.1 Performance check.....	15
9.2 Water-side maintenance	15
10 Troubleshooting	16
10.1 General errors.....	16
11 Appendices	17
11.1 Technical Data.....	17
11.2 Dimensions	18
11.3 EcoDesign Data	19
11.4 Electrical diagram	20
11.5 Declaration of conformity	23
11.6 Warranty	24

User Part

1 Introduction

The AMP water heater stores and heats water for sanitary purposes.

Cold water enters the tank through the water inlet (2). The heated water leaves the tank at the top through the hot water outlet (1). When hot water is used, the tank of the water heater is filled with the same amount of cold water.

To operate the water heater, the regulation thermostat, on each heating element, is used.

Fig. AMP water heater

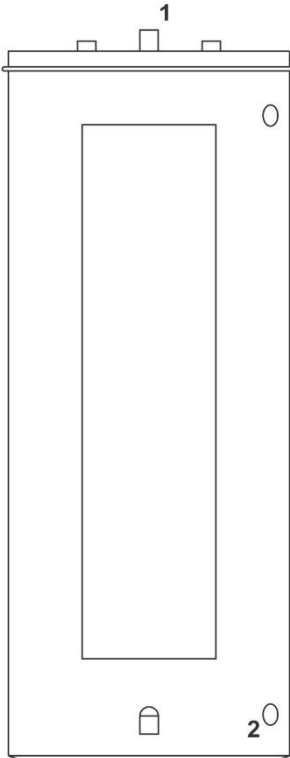

1. Water outlet
2. Water inlet

2 Safety

Lochinvar cannot be held responsible for damages or injuries due to to:

- Failing to follow the instructions provided in this manual.
- Carelessness during use or maintenance of the water heater.

Every user must study the user part of this manual and must follow the instructions in this part of the manual strictly. Do not change the sequence of the described actions. This manual must be available for the user and service engineer at all times.

Warning

If you detect a burning smell:

- Shut off the mains power supply
 - No naked flames! No smoking!
 - Open windows and doors!
 - Warn occupants and leave the building!
 - After leaving the building, alert your installation engineer.
-

Caution

Do not store or use chemical substances in the room where the water heater is installed because of the risk of explosion and corrosion of the water heater. Some propellants, bleaching agents and degreasing agents etc. disperse of explosive vapors and/or cause accelerated corrosion. If the water heater is used in a room where such substances are stored or used, the warranty will be void.

Caution

Installation, maintenance and service may only be carried out by a qualified engineer.

Caution

The water heater is not intended for use by persons with reduced physical, sensory or mental capacities, or who lack the necessary experience or knowledge.

When the person responsible for their safety is supervising or has explained how the water heater should be used, these persons can use the water heater.

Caution

This water heater is not intended to be used by children. Always supervise children, and make sure that they do not play with the water heater.

Note

Regular maintenance extends the service life of the water heater. To determine the correct service interval, the service and maintenance engineer must do a check on the water heater three months after installation. Based on this check, the best service interval can be determined.

3 Operation

3.1 Control components

To set the temperature of the AMP water heater, use the control knob of the regulation thermostat. Each electric heating element has a regulation thermostat with a control knob.

3.1.1 Temperature control

With the temperature control knob, of each regulation thermostat, you can set the desired water temperature of the water heater (see 4.1.1).

Note

It is not possible to use the temperature control knob to activate and de-activate the water heater.

3.2 Status of the water heater

The water heaters has 2 operation modes.

3.2.1 Operating modes

The AMP has 2 operating modes:

- OFF mode (see 3.2.1.1)
- ON mode (see 3.2.1.2)

3.2.1.1 OFF mode

In the **OFF mode** the water heater is de-activated. The main power supply of the water heater is set to 0.

In the **OFF mode** the water heater is not protected against frost.

3.2.1.2 ON mode

In the **ON mode** the water heater continuously responds to the heat demand. The electric heating elements are activated when there is a heat demand.

4 Use

4.1 Turn on the water heater

Caution

Make sure that the water heater is filled with water before you turn on the water heater.

To start the water heater:

1. Put the water heater in the OFF-mode
2. Open the door of the water heater.
3. Remove the foam so the controls of the water heater become visible.
4. Turn the temperature control knob of each heating element to the desired temperature.
5. Replace the foam over the controls
6. Close the door of the water heater.
7. Turn on the main power supply.

4.1.1 Temperature setting

Note

Changing the set temperature is an operation that must be carried out by a qualified service engineer/installer. Before attempting to change the temperature the appliance must be isolated from the Electric supply (OFF-mode) before the door to the controls may be opened.

Temperature in °F	Temperature in °C
120	49
130	54
140	60
150	66
160	71
170	77
180	82

Caution

Preferably the temperature control knob, on each thermostat, should be set to 60°C.

Harmful scaling and lime build-up will be higher when using position 65°C and higher. At lower temperature settings there is a higher risk of high legionella concentrations in the water.

4.2 Turn off the water heater

2.2.1 Turn off for a short period

To turn off the water heater for less than 2 months, set the water heater in the OFF mode (see 3.2.1.1).

2.2.2 Turn off for a long period

When the water heater needs to be turned off for more than 2 months, contact your service and maintenance engineer to decommission the water heater.

Installation, Maintenance and Service Part

5 Introduction

5.1 About the water heater

The AMP water heater is intended for heating water for sanitary purposes.

The AMP is a electric storage water heater. The electric heating elements transfer their heat directly to the water.

5.2 Working principle

Cold water enters the tank through the water inlet. When the water temperature drops beneath the set temperature, the electrical heating elements are activated and the water is heated. The heating elements directly transfer the heat to the water and the hot water leaves the tank through the water outlet.

The tank of the water heater has to be completely filled during operation. The tank at least must remain under mains water supply pressure at any time. Fresh cold water is immediately added when hot water is drawn from the water heater. The regulation thermostat on each heating element, is equipped with a contact thermostat. This thermostat measures the water temperature, on the outside of the tank.

6 Safety

6.1 Safety instructions

For safety instructions on the use of the water heater, refer to Safety (see 2) in the User part of this manual.

Warning

Installation, maintenance and service must be carried out by a qualified engineer in compliance with the national and local regulations.

Warning

This appliance must be installed on a non-flammable floor or surface.

Caution

The water heater may only be moved in an upright position. After unpacking, make sure that the water heater is not damaged.

Caution

Fill the water heater completely before use. Dry firing will damage the water heater.

Note

Any leakage from the tank and/or connections can cause damage to the immediate environment or floors below the level of the installation room. Install the water heater above a waste water drain or in a suitable metal leak tray.

The leak tray must have an appropriate waste water drain and must be at least 5 cm deep with a length and width of at least 5 cm larger than the water heater.

6.2 Instructions on the water heater

The water heater has some safety instructions on its cover:

- The text "A pressure relief valve must be fitted".
- The text "Mount the delivered temperature and pressure valve in this connection".
- The text "Check screwed wire connections".

6.3 Safety devices

Safety devices of the water heater:

Float switch (boil dry protection)	The float switch monitors the water level, approximately halfway up the tank, above the elements. If there is insufficient water present in the tank, then the float hangs down (reed-contact open). If the tank is filled with water then the float is moved upwards by the water (reed-contact closed).
Overheat thermostat	The overheat thermostat detects the temperature of the water in the tank. When the temperature become too high (>93°C) the thermostat locks the elements. The thermostat can be manually reset (red button) when the temperature of the water is below 20°C.

Safety devices of the installation:

Expansion valve	The expansion valve is a pressure relief valve. The expansion valve prevents excessive pressure in the tank and back flow of expansion water into the cold water main supply.
Non-return valve	The non-return valve prevents back flow of expansion water into the cold water main supply.
Pressure-reducing valve	The pressure-reducing valve reduces the water mains pressure, if necessary.
Expansion vessel	The expansion vessel is a small tank that is used to protect closed water systems from excessive pressure, due to thermal expansion of the water in the tank.
T&P valve ⁽¹⁾ (Temperature and pressure relief valve)	The T&P valve is a temperature and pressure relief valve which is activated when: <ul style="list-style-type: none">- The temperature exceeds 97°C.- The pressure exceeds 7 bar.

1- All water heaters have a T&P valve connection. Lochinvar recommends to always use a T&P valve.

6.3.1 Boil Dry Protection

The boil dry protection mechanism is a float switch which monitors the water level approximately halfway up the tank above the elements. If there is insufficient water present in the tank, the float (1) hangs downwards. If the tank is filled with water then the float is moved upwards by the water.

6.3.1.1 Working principle

The working principle is as follows: the float arm moves a magnet that is in contact with a reed-contact, which is located in the black plastic tube at the end of the float switch. The movement of the magnet and float arm changes the magnetic field and the reed-contact is opened or closed.

6.3.1.2 Exposure height

The exposure height (3) of the reed contact is very important to ensure the float switch works correctly.

The exposure height is 14 mm. This setting may not be changed!

With an exposure height of 14 mm the switch point is approximately halfway along the stroke of the float. If the exposure height is set lower, then the switch point shifts upwards. If the exposure height is too small the contact will no longer connect even if the float is completely above it. In this case the device will not come into operation. If the exposure height is set lower than 14 mm, then the switch point shifts downwards.

This means that the contact will already connect upon a small upwards movement of the float. If the exposure height is set too high then the

contact is permanently closed and the safety mechanism does not work. This means that the elements can come into operation without there being sufficient water present in the device. This will lead to the elements burning out in a very short time and short circuit and leakage. So never change the exposure height.

The reed contact and the float must always be vertical. The arrow on the clamping plate on the front must point upwards. The float switch is secured in the tank with nut (5). By loosening nut (4) the float switch can be set vertically.

Nut (4) is sealed with an o-ring with respect to nut (5). The float switch must be taken out of the device as a complete unit for checking or replacement. (The float cannot be passed through the opening in nut (5).) For this purpose the device thus has to be drained.

Fig. Float switch

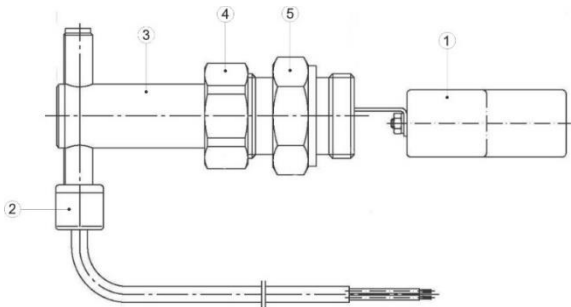

1. Float
2. Reed contact
3. Float housing (exposure height)
4. Nut
5. Nut

6.3.1.3 Checking the float switch

Switch off the feed voltage and remove the fuses from the elements. In this way the control circuit can be tested without the elements being put into operation.

Drain the device until the water is definitely below the float switch. If desired the float switch can now be removed for visual inspection. Check the resistance of the contacts with a multimeter and check whether the switch point is situated approximately halfway along the stroke of the

float. (For new contacts this resistance is between 1 and 1.5 Ohms). Screw the float switch back into the tank and place it vertically. Check the exposure height. Close the door and connect the feed voltage. The safety relays must not come in. (The opening and closing of the safety relays is clearly audible.) Now allow water to flow into the device. If the water presses the float upwards, the float switch closes the control circuit and the safety relays will close. Then drain the device once again. The lowering of the water level will lead to the float switch blocking the

control circuit once again and the safety relays will release. Repeat this operation at least one time.

Switch off the feed voltage and fit the fuses of the elements again. Close the door and reconnect the feed voltage.

6.4 Environmental aspects

6.4.1 Recycling

The packaging material is environmentally friendly, recyclable and relatively easy to discard.



6.4.2 Disposal

Old end-of-life appliances contain materials that need to be recycled. When you discard devices at the end of their service life, you must obey local legislation related to waste disposal.

Never discard your old device together with regular waste. Put the device into a municipal waste collection depot for electrical and electronic equipment. If necessary, ask your supplier or your service and maintenance engineer for advice.



7 Water heater

7.1 Structure of the water heater

The water heater has the following main components:

Tank	The water is stored and heated up in the tank.
Elements	The heating elements heat up the water.

8 Installation

Warning

The installation must be carried out by a qualified person, in compliance with general and local applicable regulations.

Caution

The water heater may not be used in rooms where chemical substances are stored or used because of the risk of explosion and corrosion of the water heater. Some propellants, bleaching agents and degreasing agents etc. disperse of explosive vapours and/or cause accelerated corrosion. If the water heater is used in a room where such substances are stored or used, the warranty will be void.

8.1 Packaging

Lochinvar recommends unpacking the water heater at or near its intended location. Remove the packaging material carefully to prevent damage to the water heater.

8.2 Conditions

The water heater must be installed, separated from living area's, with adequate ventilation

8.2.1 Ambient conditions

The installation site must be frost-free. If necessary, adjust the installation site to keep it frost-free.

Air humidity and ambient temperature	
Air humidity	Max. 93% RH at + 25 °C
Ambient temperature	Functionality: 0 < T < 40 °C

8.2.2 Maximum floor load

Refer to the building construction engineer and the general specifications in the appendices (see 11) to make sure that the maximum floor load is sufficient for the weight of the water heater.

8.2.3 Water composition

The water must comply with the regulations for drinking water for human consumption.

Water composition	
Hardness (alkaline earth ions)	> 1.00 mmol/l: - German hardness > 5.6° dH - French hardness > 10.0° fH - English hardness > 7.0° eH - CaCO ₃ > 100 mg/l
Conductivity	> 125 µS/cm
Acidity (pH value)	7.0 < pH value < 9.5

Note

Water quality may adversely affect the efficiency, performance and lifetime of the water heater,

8.3 Installation diagram

Fig. Installation diagram

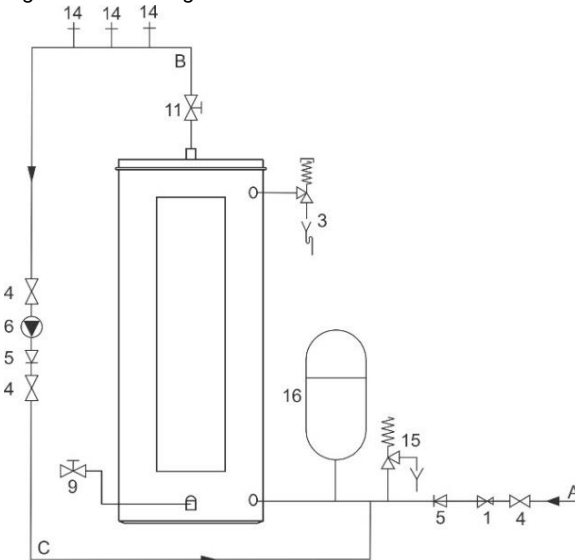

IMD-0413 R0.0

refer to Warranty (see 11.6). If water specifications differ from the specifications in the table a water treatment specialist should be consulted.

8.2.4 Working clearances

Make sure that there is sufficient clearance to access the water heater:

- 50 cm in front of the water heater.
- 50 cm at the left and right side of the water heater).
- 100 cm at the top of the water heater.

8.2.5 Placement of the water heater

Before you install the water connections and gas connections, place the water heater on the correct position and make sure that the water heater is level.

Warning

This appliance **must** be installed on a **non-flammable** floor or surface

Note

Use this installation diagram when you:

- install the water connections (see 8.4)
 - fill the water heater (see 8.6.1)
 - drain the water heater (see 8.6.2)
-

8.4 Water connections

8.4.1 Cold water connection

Install the cold-water connection:

1. Install an approved stop valve (4), as required by the applicable regulations (see 6).
2. Install an approved pressure reducing valve to prevent pressure in the cold water supply pipe exceeds the maximum working pressure of the tank, 8 bar. (Refer to the Technical details).
3. Install a non-return valve (5).
4. Install an expansion valve (15).
5. Connect the overflow connection of the expansion valve, to an open waste water pipe.
6. Install an expansion vessel (16).

8.4.2 Hot water connection

Note

Insulate long hot water pipes to prevent unnecessary energy loss.

Install the hot water connection:

1. Install a stop valve (11) in the hot water outlet pipe for service reasons.
2. If applicable, install a temperature gauge (12).
3. Install a T&P valve (3).

8.4.3 Circulation connection

Install a circulation system when an immediate flow of hot water at draw-off points is required. This improves comfort and reduces water wastage.

Note

Use the drain valve connection (9) as a connection of the circulation pipe on the water heater.

Note

Make sure that the circulation pump has the correct capacity for the length and resistance of the circulation system.

Install a circulation pump:

1. Install a circulation pump (6).
2. Install a non-return valve (5) after the circulation pump to make sure that the direction of circulation is guaranteed.
3. Install a stop valve (4) before the circulation pump.
4. Install a stop valve (4) after the non-return valve.
5. Connect the circulation pipe to the drain valve (9).

8.4.4 Drain valve

Install the drain valve:

1. Fasten the drain valve (9) in the connection in the front of the water heater.
2. Place the cap over the connection to make it watertight.

8.5 Electrical connections

Warning

Leave the water heater electrically isolated until you are ready to commission it.

8.5.1 Preparation

1. Remove the cover of the water heater
2. Remove the foam isolation to make the electrical section and the terminal block visible.

8.5.2 Mains power

Note

The water heater is supplied without a power cable and isolator.

Select and install a local electrical isolator in the main power supply of the water heater, matching the rating of the water heater.

This isolator must be installed in the same room as the appliance, suitably marked, and no more than 1 meter away from the water heater.

Connect the water heater to the mains power supply:

1. Pull the power cable through the cable gland.
2. Connect three live core to L1, L2 and L3 and the mains earth core to A.
3. Connect the power cable to the main power supply switch.
4. Secure the power cable in the cable gland.

Note

The length of the mains earth core that is connected to the electrical connection must be longer than the core of the mains live (L1, L2 and L3).

8.6 Commissioning

To commission the water heater:

1. Fill the water heater (see 8.6.1)
2. Turn on the water heater (see 8.6.2)

8.6.1 Filling

Refer to the installation diagram (see 8.3) when you fill the water heater:

1. Open the stop valve (11) in the hot water supply pipe.
2. If applicable, open the stop valves (4) of the circulation pipe (C).
3. Make sure that the drain valve (9) is closed.
4. Open all hot water draw-off points (14) to bleed the entire installation of air.
5. Open the valve (14) in the cold water supply pipe (A). Cold water flows into the water heater.
6. Fill the water heater until cold water flows out of all opened draw-off points. The water heater is completely full.
7. Make sure that no water comes out of the expansion valve (15) or the T&P valve (3). If water comes out:
 - Examine if the water supply pressure is greater than the specified value in the Technical details. If necessary, install a pressure reducing valve (1).
 - Examine if the pressure relief valve of the inlet security group in the protected cold supply set-up is installed correctly and is not defect. If necessary, replace the expansion valve.
8. Close all hot water draw-off points.

8.5.2 Turn on the water heater

Refer to the procedure in the user part to Turn on the water heater (see 4.1).

8.7 Decommissioning

To decommission the water heater:

1. Turn off the water heater (see 8.6.1)
2. Drain the water heater (see 8.6.2)

8.7.1 Turn off the water heater

Refer to the procedure in the user part to Turn off the water heater (see 4.2).

8.7.2 Draining

Refer to the installation diagram (see 8.3) when you drain the water heater:

1. If applicable, close the service stop valve (11) in the hot water pipe.
2. Close the stop valve (4).
3. Open the drain valve (9).
4. Aerate the entire installation of air until the water heater is completely drained.

Note

Disconnect and tilt the water heater in the direction of the drain valve when the water heater needs to be drained completely.

9 Maintenance

The water heater needs maintenance at least once a year. The maintenance interval is determined by the water quality, the average operation hours each day and the set water temperature.

To determine the correct interval, Lochinvar recommends doing a system check three months after installation.

Note

Do maintenance to maintain an effective and efficient transfer of heat to the water. This significantly increases the service life of the water heater.

Note

When needed, spare parts can be ordered. To be sure that you receive the correct spare parts, look at the data plate for the full serial number, the water heater model. Use this information when you order the spare parts.

Do the following maintenance activities:

- Performance check (see 9.1)
- Water-side maintenance (see 9.2)

9.1 Performance check

Check if the performance of all components is correct:

1. Make sure that the water heater cycle operates correctly.
2. If applicable, make sure that the T&P valve operates correctly.
3. Open the T&P valve pressure relief and make sure that water flows from the outlet.

Warning

Hot water can come out of the T&P valve.

5. Make sure the pressure relief connection of the inlet security group operates correctly. Open this pressure relief and make sure that water spurt out.

9.2 Water-side maintenance

To do water side maintenance:

- Inspect the anode (see 9.2.1)
- Descale the tank (see 9.2.2)

9.2.1 Inspect the anode

The life cycle of the anode is determined by the quality and the quantity of the water that flows through the water heater. Inspect the anode at least once a year to make sure that the tank is protected against corrosion.

To inspect the anode:

1. Close the pressure reducing valve in the cold water supply.
2. Open the nearest hot water tap to reduce the water pressure in the water heater.
3. Use a wrench to loosen the anode.
4. Take the anode out of the water heater.

5. Inspect the volume of the anode. When the anode is consumed for 40 % or more replace the anode.

Note

If the anode needs to be replaced, always use an anode of the same type. Please refer to the type and the serial number on the data plate.

6. Place the anode in the water heater.
7. Use a wrench to fasten the anode.
8. Make sure that the connection is watertight.

Note

Never install an anode isolated from the metal tank.

9.2.2 Descale the tank

Use a descaling agent if necessary remove lime and dirt from the tank. Contact Lochinvar Technical support for advice about which descaling agent to use. Lochinvar service department can carry out this function if required, please contact us for further information.

9.2.3 Finalization

When all maintenance activities are finished, place the outer door back on the water heater. After that:

1. If necessary, fill the water heater (see 8.7.1).
2. Turn on the water heater (see 8.7.3).

10 Troubleshooting

10.1 General errors

Fault	Cause	Solution
Insufficient or no hot water	Temperature set too low	Set regulating thermostats higher.
	Overheat thermostat break the circuit.	Press in reset button.
	Connector is not seated in stop contact, mains switch is off or fuses are broken.	Check the relevant parts.
	Cause cannot be ascertained.	Switch off device and ask for help from technical support
Leakage	Insufficient sealing of the water connections.	Tighten the screw thread connections.
	Leakages from other water devices or pipes nearby.	Trace the cause

11 Appendices

11.1 Technical Data

Type	Unit	AMP200-9	AMP200-18	AMP200-36
Tank capacity	ltr.	200	200	200
Number of elements	-	3	3	6
Power 380V-3F	kW	7.6	15.2	30.3
Power 400V-3F	kW	8.4	16.8	33.6
Power 414V-3F	kW	9.0	18.0	36.0
Heating time up to 60°C * (400 / 414V)	min.	83/78	42/39	21/19
Heating time up to 40°C * (400 / 414V)	min.	50/47	25/23	12/12
Tap capacity 1st hour 60°C ** (400 / 414V)	ltr.	368/377	505/525	780/819
Tap capacity continuous 60°C ** (400 / 414V)	ltr/hr	145/155	289/310	578/619
Tap capacity 1st hour 40°C ** (400 / 414V)	ltr.	613/629	842/874	1299/1364
Tap capacity continuous 40°C (400 / 414V)	ltr/hr	241/258	482/516	963/1032
Weight	kg	73	73	73

Type	Unit	AMP300-9	AMP300-18	AMP300-36	AMP300-54
Tank capacity	ltr.	300	300	300	300
Number of elements	-	3	3	6	9
Power 380V-3F	kW	7.6	15.2	30.3	45.5
Power 400V-3F	kW	8.4	16.8	33.6	50.4
Power 414V-3F	kW	9.0	18.0	36.0	54.0
Heating time up to 60°C * (400 / 414V)	min.	125/116	62/58	31/29	21/19
Heating time up to 40°C * (400 / 414V)	min.	75/70	37/35	19/17	12/12
Tap capacity 1st hour 60°C ** (400 / 414V)	ltr.	483/493	620/640	895/934	1169/1228
Tap capacity continuous 60°C ** (400 / 414V)	ltr/hr	145/155	289/310	578/619	867/929
Tap capacity 1st hour 40°C ** (400 / 414V)	ltr.	805/821	1034/1066	1491/1556	1949/2047
Tap capacity continuous 40°C (400 / 414V)	ltr/hr	241/258	482/516	963/1032	1445/1548
Weight	kg	110	110	110	110

* From 10°C cold water

** After heating time up to 60°C from 10°C and assuming a tap efficiency of 80°C

11.2 Dimensions

	Description	AMP200	AMP300
A	Height hot water connection	1460	1580
B	Height of upper side of device	1420	1540
D	Diameter of water heater	560	640
E	Depth	690	790
M	Height of drain valve	125	125
R	Height cold water supply	125	125
S	Height T&P connection	1230	1335
1	Cold water connection	1¼"-14NPT	1¼"-14NPT
2	Hot water connection	1¼"-14NPT	1¼"-14NPT
3	T&P connection	¾"-14NPT	¾"-14NPT
4	Drain plug connection	¾"-14NPT	¾"-14NPT

All dimensions are in mm (rounded up to 10 mm).

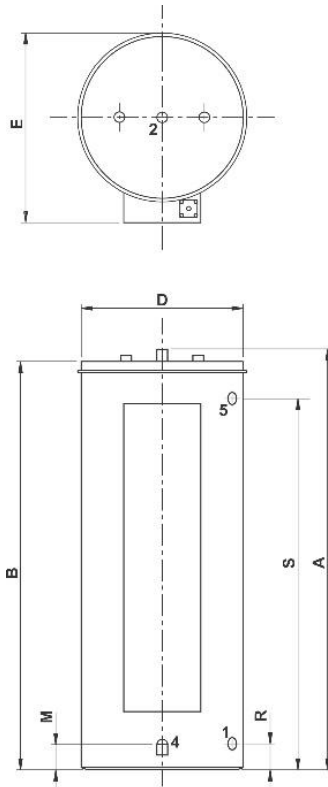

11.3 EcoDesign Data

Description	Unit	AMP200-9	AMP200-18	AMP200-36
Load Profile	-	XL	XL	XL
Energy Efficiency Class	-	C	C	C
Water Heating Efficiency	%	38.0	38.0	38.0
Daily Electricity Consumption	kWh	20.161	20.161	20.161
Daily Fuel Consumption	kWh GCV	0.000	0.000	0.000
Mixed Water 40°C (V40)	ltr.	240	465	∞
Additional Load Profile	-	-	-	-
Energy Efficiency	%	-	-	-
Daily Electricity Consumption	kWh	-	-	-
Daily Fuel Consumption	kWh GCV	-	-	-
Mixed Water 40°C (V40)	ltr.	-	-	-

Description	Unit	AMP300-9	AMP300-18	AMP300-36	AMP300-54
Load Profile	-	XL	XL	XL	XL
Energy Efficiency Class	-	C	C	C	C
Water Heating Efficiency	%	38.4	38.4	38.4	38.4
Daily Electricity Consumption	kWh	20.120	20.120	20.120	20.120
Daily Fuel Consumption	kWh GCV	0.000	0.000	0.000	0.000
Mixed Water 40°C (V40)	ltr.	420	720	∞	∞
Additional Load Profile	-	-	-	-	-
Energy Efficiency	%	-	-	-	-
Daily Electricity Consumption	kWh	-	-	-	-
Daily Fuel Consumption	kWh GCV	-	-	-	-
Mixed Water 40°C (V40)	ltr.	-	-	-	-

11.4 Electrical diagram

Fig. 3 phases/3 elements (9 kW)

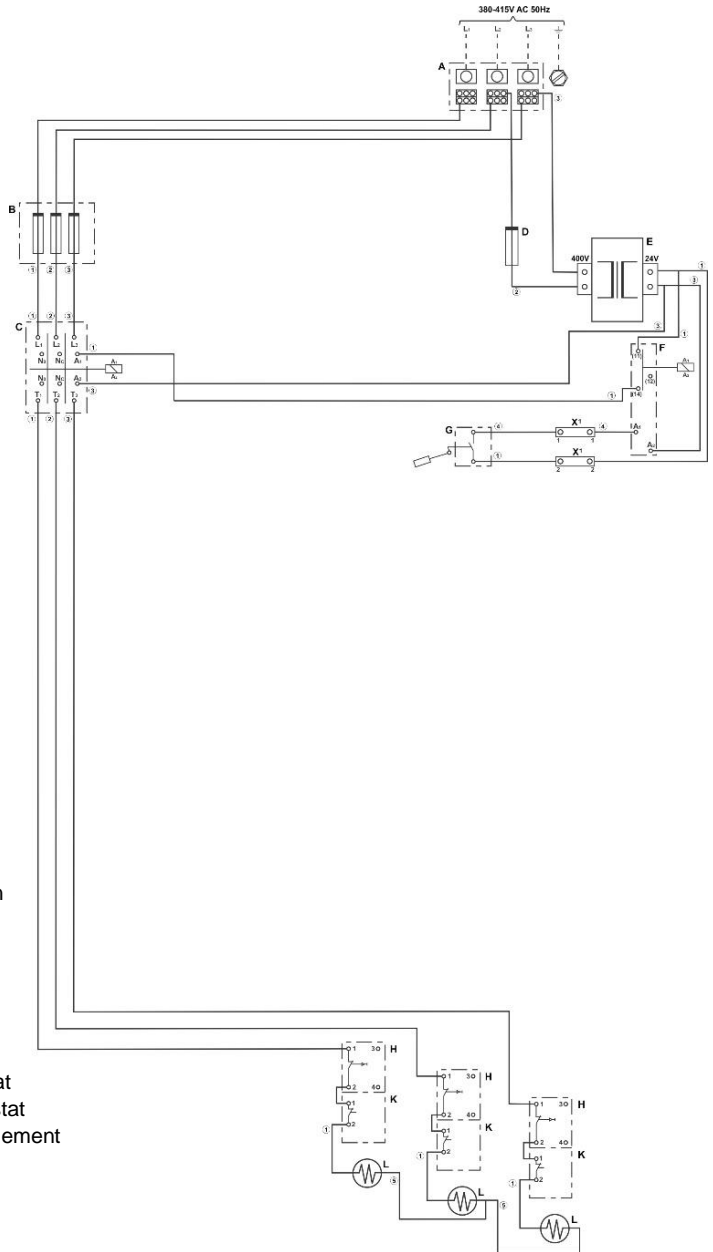

- A = Network connection
- B = Fuses
- C = Relay
- D = Fuse
- E = Transformer
- F = Safety relay
- G = Float switch
- H = Overheat thermostat
- K = Regulation thermostat
- L = Electrical heating element
- X1 = Terminal block
- 1 = Black
- 2 = Red
- 3 = Blue
- 4 = Brown
- 5 = Yellow

0310149 R0.0

Fig. 3 phases/6 elements (18 and 36 kW)

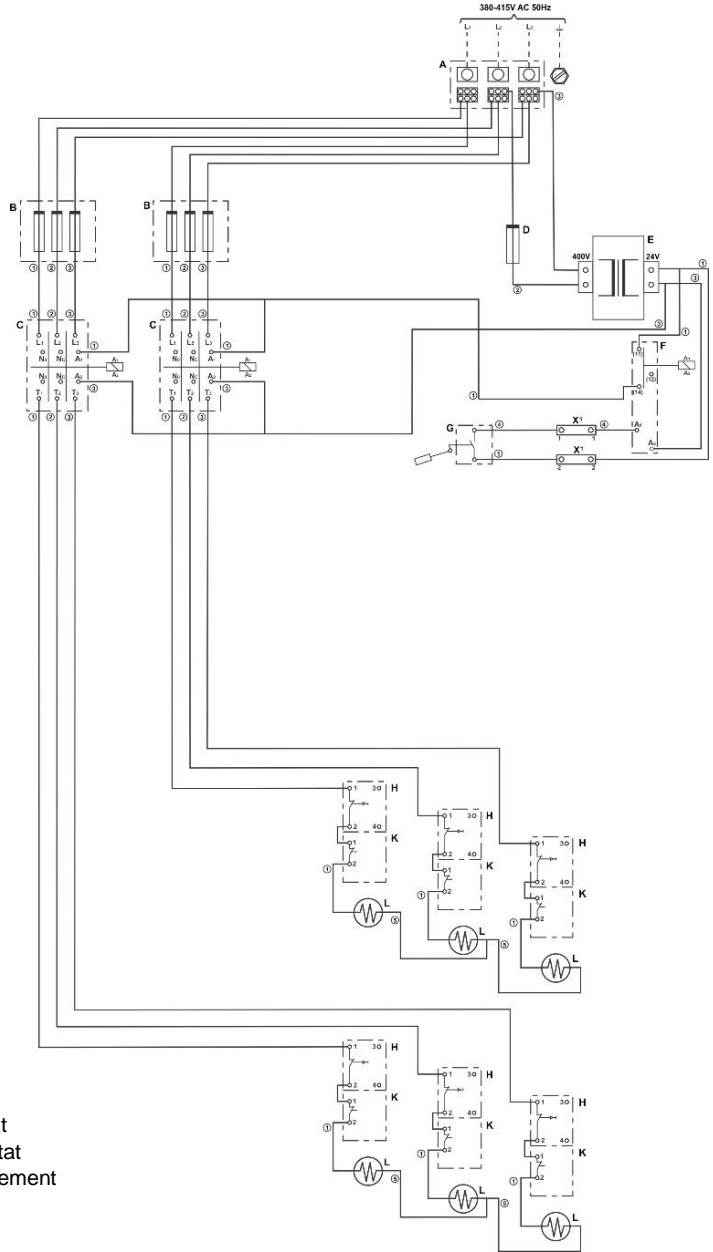

- A = Network connection
- B = Fuses
- C = Relay
- D = Fuse
- E = Transformer
- F = Safety relay
- G = Float switch
- H = Overheat thermostat
- K = Regulation thermostat
- L = Electrical heating element
- X1 = Terminal block
- 1 = Black
- 2 = Red
- 3 = Blue
- 4 = Brown
- 5 = Yellow

0310150 R0.0

Fig. 3 phases /9 elements (54 kW)

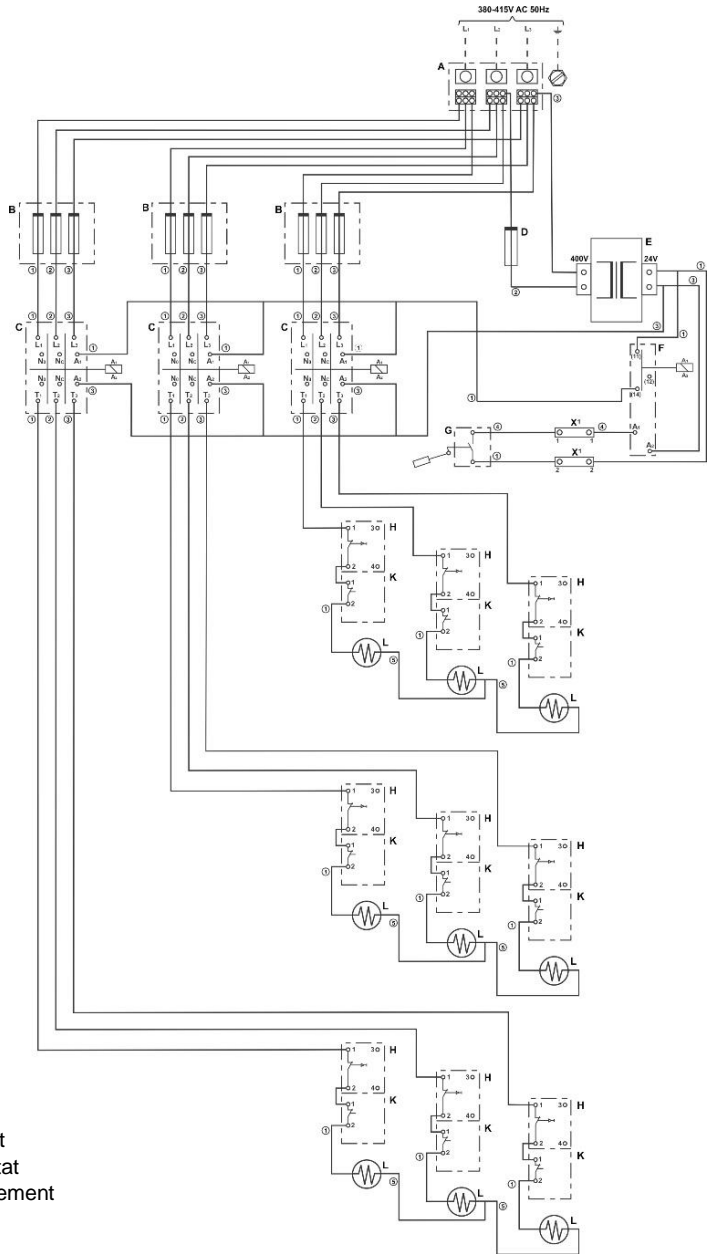

- A = Network connection
- B = Fuses
- C = Relay
- D = Fuse
- E = Transformer
- F = Safety relay
- G = Float switch
- H = Overheat thermostat
- K = Regulation thermostat
- L = Electrical heating element
- X1 = Terminal block
- 1 = Black
- 2 = Red
- 3 = Blue
- 4 = Brown
- 5 = Yellow

0310151 R0.0

11.5 Declaration of conformity



EEC - Declaration of Conformity

Supplier: Lochinvar Limited
7 Lombard Way
The MXL Centre
Banbury - United Kingdom

hereby declares that the following products:

Product description: Commercial Electric Water Heater
Product family name: Cavalier
Product models: AMP 200-9, AMP 200-18, AMP 200-36,
AMP 300-9, AMP 300-18, AMP 300-36, AMP 300-54

on the assumption that the installation instructions have been followed are compliant to:

- **Low Voltage Directive (LVD) - 2006/95/EG**
 - EN 60335-1:2002 + A11:2004 + A1:2004 + A12:2006 + A2:2006 + A13:2008
 - EN 60335-2-21:2003 + A1:2005 + A2:08
 - EN 62233:2008-12-17 + A1:08
- **Pressure Equipment Directive (PED) - 2014/68/EG**
 - Based on Art. 4, Sub 3. (PS < 10 bar, pressure vessel for non-hazardous fluids)
- **ECO Design Directive (ErP) - 2009/125/EG**
 - Commission regulation No. 814/2013 based on notices 2014/C - 207/03
- **Energy Labelling Directive - 2010/30/EG**
 - Commission regulation No. 812/2013

Company:
Lochinvar Limited

Date:
October 1, 2019

Signature:

E. van Driel
Managing Director

11.6 Warranty

Article 1: General warranty

If within 1 (one) year of the invoice date or commissioning date of a water heater supplied by Lochinvar Ltd., following verification, and at the sole discretion of Lochinvar Ltd., an assembly or part (with exclusion of the tank) proves to be defective or fails to function correctly due to manufacturing and/or material defects, then Lochinvar Ltd. shall repair or replace this assembly or part.

Article 2: Tank warranty

If within 3 (three) years of the invoice date or commissioning date of a water heater supplied by Lochinvar Ltd, following verification, and at the sole discretion of Lochinvar Ltd, the enamel-lined steel tank proves to be leaking due to rust or corrosion occurring on the water side, then Lochinvar Ltd shall offer to replace the defective water heater with an entirely new water heater of equivalent size and quality. The warranty period given on the replacement water heater shall be equal to the remaining warranty period of the original water heater that was supplied. Lochinvar Ltd will only grant warranty on the tank after inspection in one of the laboratories of Lochinvar Ltd.

Article 3: Conditions for Installation and Use

The warranty set out in articles 1 and 2 will apply solely under the following conditions:

- The water heater is installed under strict adherence to Lochinvar Ltd installation instructions for the specific model, and must be in accordance with the relevant requirements of the Gas Safety Regulations, Building Regulations, I.E.E. Regulations and the byelaws of the local water undertaking. The installation should also be in accordance with any relevant requirements of the local gas distributor and local authority.
- The water heater remains installed at the original site of installation.
- The water heater is used exclusively with drinking water, which at all times can freely circulate (a separately installed heat exchanger is mandatory for heating saline water or corrosive water).
- The tank is safeguarded against harmful scaling and lime build-up by means of periodic maintenance.
- The water temperatures in the heater do not exceed the maximum setting of the thermostats, which form a part of the water heater.
- The water pressure and/or heat load do not exceed the maximum values stated on the water heater rating plate.
- The water heater is installed in a non-corrosive atmosphere or environment.
- The water heater is connected to a protected cold supply arrangement, which is: approved by the relevant authority; with sufficient capacity for this purpose; supplying a pressure no greater than the working pressure stated on the water heater; and where applicable by a likewise approved temperature and pressure relief valve, fitted in accordance with installation instructions of Lochinvar Ltd applying to the specific model of water heater, and further in compliance with Building Regulations, local authority installation byelaws and the Water Supply (Water Fittings) Regulations 1999 .
- The water heater is fitted with cathodic protection in the form of sacrificial Magnesium anodes. In case the anodes have reduced in size by more than 40% at any point along their length or if they are severely pitted, new anodes should be fitted. Particular attention should be paid to the ends of each anode to ensure excessive localized depletion has not occurred. Where anodes are covered with particles they should be cleaned; for reference, when new, the anode has a diameter of 21 mm. When power anodes are used, it is important to ensure that they continue to work properly.

Article 4: Exclusion

The warranty set out in articles 1 and 2 will not apply in the event of:

- Damage to the water heater caused by an external factor;
- Misuse, neglect (including frost damage), modification and incorrect and/or unauthorized use of the water heater;
- Contaminants or other substances having been allowed to enter the tank;
- Any attempts at repair to a defective water heater other than by an approved service engineer.
- Damage caused by lack of maintenance and / or excessive amounts of scale inside the unit.
- The conductivity of the water being less than 125 $\mu\text{S}/\text{cm}$ and/or the hardness (alkaline earth ions) of the water being less than 1.00 mmol/litre;
- Unfiltered, recirculated water flowing through or being stored in the water heater.

Article 5: Scope of the warranty

The obligations of Lochinvar Ltd. pursuant to the specified warranty are limited to free delivery from the warehouse of the replacement assemblies, parts or water heater, respectively. Labour, installation and any other costs associated with the replacement will not be accepted by Lochinvar Ltd.

Article 6: Claims

A claim on grounds of the specified warranty must be submitted to the dealer from whom the water heater was purchased, or to another authorized dealer of Lochinvar Ltd. Inspection of the water heater as referred to in articles 1 and 2 shall take place in one of the laboratories of Lochinvar Ltd.

Article 7: Obligations of Lochinvar Ltd.

Lochinvar Ltd. grants no other warranty or guarantee over its water heaters nor the (assemblies or parts of) water heaters supplied for replacement, other than the warranty expressly set out in these conditions. Under the terms of the supplied warranty, Lochinvar Ltd. is not liable for damage to persons or property caused by (assemblies or parts, or the glass-lined steel tank of) a (replacement) water heater that it has supplied.



7 Lombard Way, The MXL Centre, Banbury, Oxon, OX16 4TJ
Tel: +44(0) 1295 269 981, Fax:+44(0) 1295 271 640, Email: info@lochinvar.ltd.uk
www.lochinvar.ltd.uk

Lochinvar Ltd reserves the right to change specifications without prior notice